

PRACTICAL PHYSICS

S. Y. B. Sc. PHYSICS (PH 223) • PAPER III

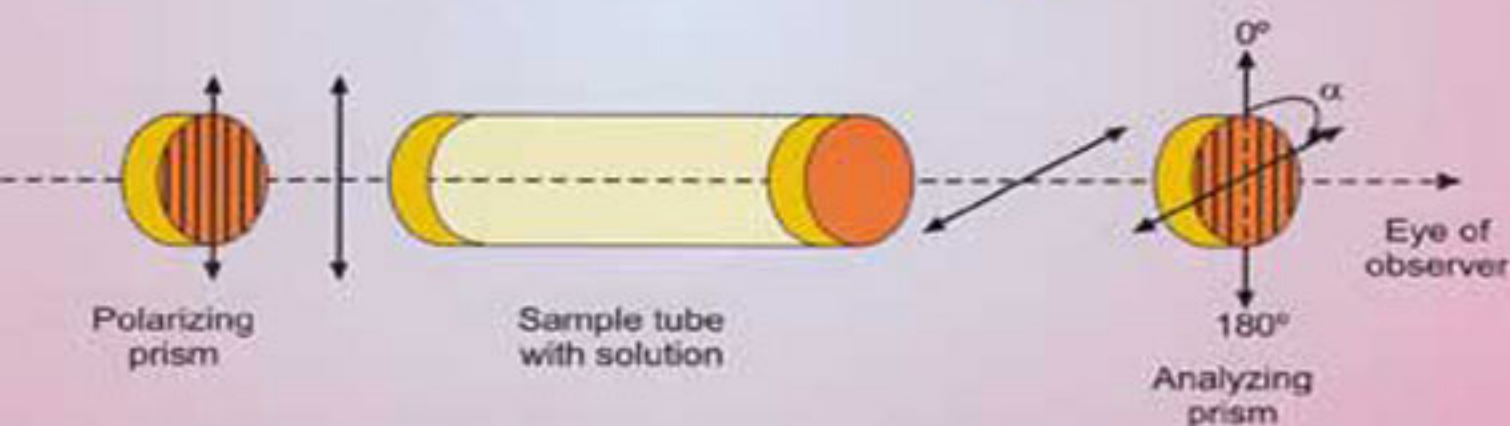
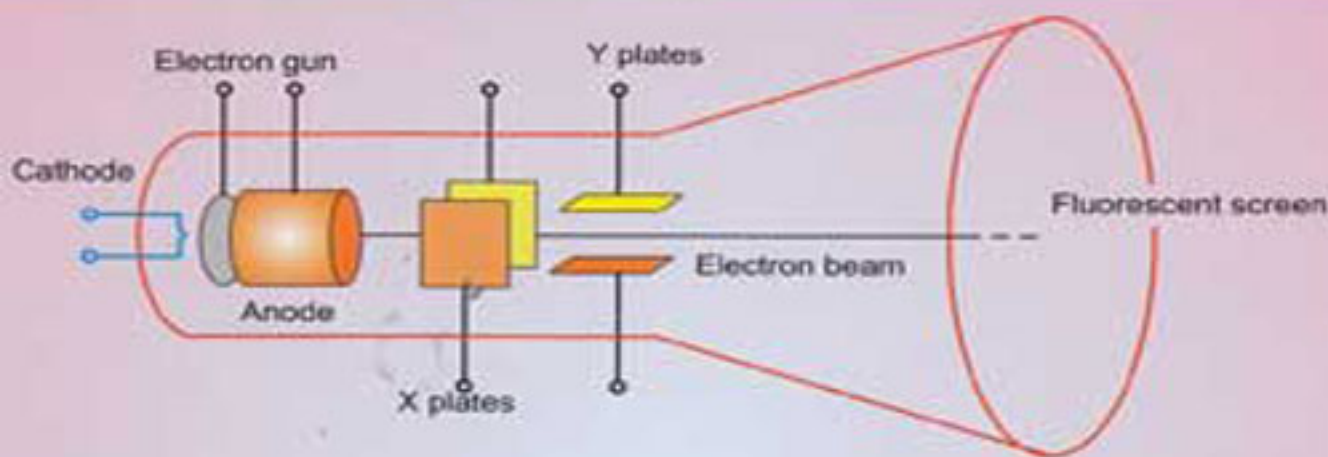

A. B. BHISE

R. B. BHISE

PRACTICAL PHYSICS

**ACCORDING TO NEW REVISED SYLLABUS OF SAVITRIBAI PHULE
PUNE UNIVERSITY FROM JUNE-2014**

FOR S. Y. B. Sc.

BY

Dr. A. B. BHISE

(M.Sc. M.Phil. Ph.D.)
Ex-Head,
Department of Physics
C. T. Bora College, Shirur
Tal : Shirur, Dist : Pune

R. B. BHISE

(M.Sc. M.Phil. DCM)
Head,
Department of Physics
B. J. A. C. S. College, Ale
Tal : Junnar, Dist : Pune

Price ₹ 95.00

 **NIRALI**[®]
PRAKASHAN
ADVANCEMENT OF KNOWLEDGE

N2275

S.Y.B.Sc. PRACTICAL PHYSICS

ISBN 978-93-5164-462-0

Second Edition : July 2015

© : Authors

The text of this publication, or any part thereof, should not be reproduced or transmitted in any form or stored in any computer storage system or device for distribution including photocopy, recording, taping or information retrieval system or reproduced on any disc, tape, perforated media or other information storage device etc., without the written permission of Authors with whom the rights are reserved. Breach of this condition is liable for legal action.

Every effort has been made to avoid errors or omissions in this publication. In spite of this, errors may have crept in. Any mistake, error or discrepancy so noted and shall be brought to our notice shall be taken care of in the next edition. It is notified that neither the publisher nor the authors or seller shall be responsible for any damage or loss of action to any one, of any kind, in any manner, therefrom.

Published By :
NIRALI PRAKASHAN CMS INFO SYSTEMS PVT. LTD.

Abhyudaya Pragati, 1312, Shivaji Nagar,
Off J.M. Road, PUNE – 411005
Tel - (020) 25512336/37/39, Fax - (020) 25511379
Email : niralipune@pragationline.com

Printed By :

Agarkar Bhavan, LBS Road,
Pune 411030
Tel – (020) 30116764

 **DISTRIBUTION CENTRES**

PUNE

Nirali Prakashan : 119, Budhwar Peth, Jogeshwari Mandir Lane, Pune 411002, Maharashtra
Tel : (020) 2445 2044, 66022708, Fax : (020) 2445 1538
Email : bookorder@pragationline.com, niralilocal@pragationline.com

Nirali Prakashan : S. No. 28/27, Dhyari, Near Pari Company, Pune 411041
Tel : (020) 24690204 Fax : (020) 24690316
Email : dhyari@pragationline.com, bookorder@pragationline.com

MUMBAI

Nirali Prakashan : 385, S.V.P. Road, Rasdhara Co-op. Hsg. Society Ltd.,
Girgaum, Mumbai 400004, Maharashtra
Tel : (022) 2385 6339 / 2386 9976, Fax : (022) 2386 9976
Email : niralimumbai@pragationline.com

 **DISTRIBUTION BRANCHES**

JALGAON

Nirali Prakashan : 34, V. V. Golani Market, Navi Peth, Jalgaon 425001,
Maharashtra, Tel : (0257) 222 0395, Mob : 94234 91860

KOLHAPUR

Nirali Prakashan : New Mahadvar Road, Kedar Plaza, 1st Floor Opp. IDBI Bank
Kolhapur 416 012, Maharashtra. Mob : 9850046155

NAGPUR

Pratibha Book Distributors : Above Maratha Mandir, Shop No. 3, First Floor,
Rani Jhanshi Square, Sitabuldi, Nagpur 440012, Maharashtra
Tel : (0712) 254 7129

DELHI

Nirali Prakashan : 4593/21, Basement, Aggarwal Lane 15, Ansari Road, Daryaganj
Near Times of India Building, New Delhi 110002
Mob : 08505972553

BENGALURU

Pragati Book House : House No. 1, Sanjeevappa Lane, Avenue Road Cross,
Opp. Rice Church, Bengaluru – 560002.
Tel : (080) 64513344, 64513355, Mob : 9880582331, 9845021552
Email: bharatsavla@yahoo.com

CHENNAI

Pragati Books : 9/1, Montieth Road, Behind Taas Mahal, Egmore,
Chennai 600008 Tamil Nadu, Tel : (044) 6518 3535,
Mob : 94440 01782 / 98450 21552 / 98805 82331,
Email : bharatsavla@yahoo.com

niralipune@pragationline.com | www.pragationline.com

Also find us on  www.facebook.com/niralibooks

PREFACE

We are happy to place this book “**S.Y.B.Sc. Physics Practical**” in the hand of B.Sc. students and teachers of Savitribai Phule Pune University. This book envisages the revised syllabus which is implemented from the academic year 2014-15. It is general impression of physics students that physics practicals are very difficult, hence the experimental matter is prescribed in a simple and lucid manner with the help of neat and clear figures of instruments.

This book gives a brief description of physics experiments which are chosen as per the latest curriculum. The experiments include oscillations, waves, sound, optics, electronics, instrumentation, computer and demonstration. Each experiment is discussed with Aim, Apparatus, Diagram, Procedure, Observation, Observation table, Formulae and Results. The theory of experiment is presented in brief in the principle with necessary formulae and their explanation.

At the end of each experiment necessary Oral Questions, Tables and Graphs are included. We think that the students will find this book most useful while performing the experiments.

We are thankful to Mr. Ashok Bodake, Sachin Shinde, Nilesh Deshmukh, Nitin Thorat, Mohasin Sayyed, Ravindra Walodare, Varsha Bodake, Santosh Bare, and Prachi Sawant for their efforts and encouragement. We are also thankful to Dnyaneshwar Gramonnati Mandal, B. J. College, Ale (PUNE) and C.T. Bora College, Shirur (PUNE) for their co-operation and encouragement. We must gratefully acknowledge the patience and understanding shown by our family members during this endeavor.

Our sincere thanks are to Shri. Dineshbhai Furia, Shri Jignesh Furia and whole staff of Nirali Prakashan for their co-operation, nice printing, constant encouragement and efforts in bringing out this book.

Any suggestion for improvements of the book shall be most welcome.

Author - Bhise R.

Dedicated
to
my Mother
Gangubai

SYLLABUS

The syllabus of Savitribai Phule Pune University for S.Y.B. Sc. (Physics Practical, Paper-III) from academic year 2014-2015 is as follows.

SECTION (I) OR GROUP (A)

GENERAL PHYSICS

1) Oscillations, Waves and Sound (Any 4 experiments)

1. Logarithmic decrement (in air and water)
2. Study of coupled oscillators comprising two simple pendulum (mechanical) and determination of coupling coefficient.
3. Study of musical scales using a signal generator and musical instruments.
4. Determination of frequency of AC mains using sonometer.
5. Measurement of coefficient of absorption of sound for different materials (cork, thermocol, mica, paper etc.)
6. Velocity of sound by phase shift method.
7. Determination of speed of sound by Quincke's method interferometer.
8. Directional characteristics of Microphone.

2) Optics (Any 4 experiments)

1. Newton's Rings : Determination of wavelength of monochromatic light source (λ)
2. Dispersive power of glass prism
3. Total internal reflection (using a LASER beam and glass prism).
4. Diffraction at the edge of a razor blade.
5. Optical activity of sugar solution (polarimeter)
6. Goniometer to determine cardinal points and focal length.
7. To determine temperature of sodium flame.
8. Double refracting prism.

SECTION (II) OR GROUP (B)

ELECTRONICS AND COMPUTER

1) Electronics/Instrumentation (Any 6 experiments)

1. Circuit Theorems. (Thevenin's, Norton's and Maximum power transfer theorems)
2. Transistor characteristics (CE configuration).

3. Transistor amplifier (single stage)
4. Study of rectifiers (half wave and full wave) with different filters.
5. I-V characteristics of UJT
6. UJT as a Relaxation Oscillator.
6. Zener as a regulator, line and load regulation.
7. Study of phase shift oscillator (using IC 741)
8. OPAMP as inverting and non-inverting amplifier
9. OPAMP as an audio mixer.
10. Study of logic gates (using IC) and verification of De Morgan's theorem.
11. Use of CRO (AC/DC voltage measurement, frequency measurement).
12. To measure displacement (linear and angular) using potentiometer/variable inductor/variable capacitor.
13. To measure force using load cell.
14. To measure pressure using elastic diaphragm (in variable capacitor/Bourden tube)
15. To measure magnetic field using Hall probe for a system of ring magnets.

2) Computer (Any 2 experiments)

1. Plotting various trigonometric functions using spreadsheet/any graphic software : $\sin(\theta)$, $\cos(\theta)$, $\tan(\theta)$, e^y , e^{-y} , $\log(x)$, $\ln(x)$, x^n
2. Equations for the following figures : circle, ellipse, parabola, hyperbola.
3. Inverse, determinant of matrix, solution of linear equations.

Additional Activities (Any Two)

1. Demonstrations - Any 4 demonstrations equivalent to 2 experiments
2. Study tour with report equivalent to 2 experiments
3. Mini project equivalent to 2 experiments
4. Computer aided demonstrations (Using computer simulations or animations)
(Any 2 demonstrations equivalent to 2 experiments)

Students have to perform at least two additional activities in addition to sixteen experiments mentioned above. Total laboratory work with additional activities should be equivalent to twenty experiments.



CONTENTS

SECTION (I) GENERAL PHYSICS

* Introduction	I.1 to I.6
1. Logarithmic decrement (in air and water)	1
2. Study of coupled oscillators comprising two simple pendulum (mechanical) and determination of coupling coefficient.	4
3. Determination of frequency of AC mains using sonometer.	7
4. Directional characteristics of Microphone.	10
5. Newton's Rings : Determination of wavelength of monochromatic light source (λ)	13
6. Dispersive power of glass prism	18
7. Total internal reflection (using a LASER beam and glass prism).	22
8. Diffraction at the edge of a razor blade.	27
9. Measurement of coefficient of absorption of sound for different materials (cork, thermocol, mica, paper etc.)	31
10. Velocity of sound by phase shift method.	35
11. Optical activity of sugar solution (polarimeter).	39
12. Double refracting prism.	44

SECTION (II) ELECTRONICS/ INSTRUMENTATION AND COMPUTER

1. Circuit Theorems. (Thevenin's, Norton's and Maximum power transfer theorem)	47
2. Transistor characteristics (CE configuration).	52
3. Transistor amplifier (single stage)	56
4. Study of rectifiers (half wave and full wave) with different filters.	60
5. I-V characteristics of UJT	65
6. UJT as a relaxation oscillator.	68
7. Zener as a regulator, line and load regulation.	70
8. Study of phase shift oscillator (using IC 741)	74
9. OPAMP as inverting and non-inverting amplifier	78
10. Study of logic gates (using IC) and verification of De Morgan's theorems.	82
11. Use of CRO (AC/DC voltage measurement, frequency measurement).	86
12. Plotting various trigonometric functions using spreadsheet/any graphic software : $\sin(\theta)$, $\cos(\theta)$, $\tan(\theta)$, e^y , e^{-y} , $\log(x)$, $\ln(x)$, x^n	90

OTHER ACTIVITY

1. Computer Demo



INTRODUCTION

General Instructions :

It is necessary for the student to know beforehand what experiment he has to do and how he can do it best in laboratory. Following preparation work has to be done before an experiment is actually taken up.

- 1) To know the precautions to be taken to handle the experiments.
- 2) To know the theory of experiments.
- 3) To know the unit of measurement quantities in experiments.
- 4) To acquire a knowledge of the working principle of all the experiments.
- 5) To prepare a schedule according to which observations are to be made.

As a rule, Care should be taken to carry a piece of apparatus from one place to another and several observations should be made for any measurement. The operations should be conducted methodically. When the experiment is over, the different pieces of apparatus used should be left in proper condition.

Rough notebook (Recording of Data) :

All data taken during an experiment should be recorded accurately and systematically in tabular form in a rough practical notebook. Rough practical notebook is a book for recording the original and actual data. Rough practical notebook contains date on which the experiment was performed, name of experiments, apparatus used in experiments, a sketch of arrangement of experiments, theory of experiments, brief description of special apparatus used, method or procedure of performing the experiments, tables of data, graphical results, brief discussion of results, errors in results and its causes and final results with daily sign by supervisor.

Error :

An error is a deviation from accuracy or correctness. A mistake is an error caused by a fault. The fault is due to misjudgement, carelessness or forgetfulness in the practical data reading. Error is that may occur in the execution of a statistical experiment design. Types of experimental error include human error or mistakes in data entry, systematic error or mistakes in the design of the experiment itself or random error caused by environmental conditions or other unpredictable factors. Experiment design seeks to minimize experimental error, in order to produce the most accurate data possible.

Graphs :

A graph is depicted in diagrammatic form as a set of dots for the vertices joined by lines or curves for the edges. The interconnected objects are represented by mathematical abstractions called vertices and the links that connect some pairs of vertices are called edges. Whenever possible the results of the experiments should be represented by suitable graphs. In graphs, the points plotted should always be clearly marked; curve drawn

should be smooth, passing through as many points as possible. The points lying outside the curve should be evenly distributed on both sides of it, so that it is a mean curve.

Least Count :

It is a ratio of value of one main scale division to total number of head scale divisions.

Vernier Caliper :

It is a precision instrument that can be used to measure internal and external distances extremely accurately. A Vernier scale is a device that lets the user measure more precisely than could be done unaided when reading a uniformly-divided straight or circular measurement scale. It is a scale that indicates where the measurement lies in between the two of the marks on the main scale. The Vernier caliper is an extremely precise measuring instrument. Close the jaws tightly on the object to be measured. If you are measuring something with a round cross section, make sure that the axis of the object is perpendicular to the caliper.

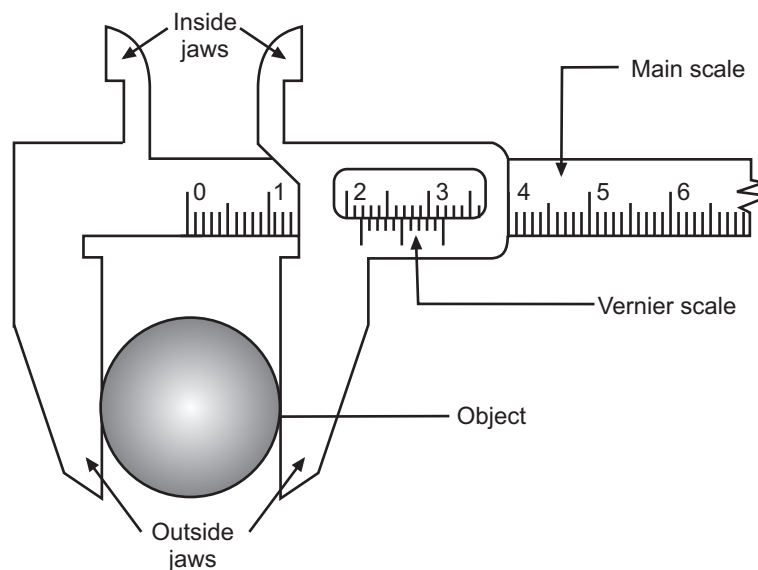
**Micrometer screw gauge :**

It is a precision instrument. It is used for measuring diameter of circular objects mostly wires, with an accuracy of 0.001cm. It consists of a hollow cylinder mounted on a U frame. The hollow cylinder leads to a ratchet which is meant for fine adjustment. The U frame consists of a flat end known as stud and a screw on the other side. This screw can be moved inside the nut fitted in the U frame by rotating the hollow cylinder called the thimble. This is called the main scale. The hollow cylinder or the thimble is graduated into 50 or 100 equal parts. This is called the circular scale. Micrometer screw-gauge is another instrument used for measuring accurately the diameter of a thin wire or the thickness of a sheet of metal.

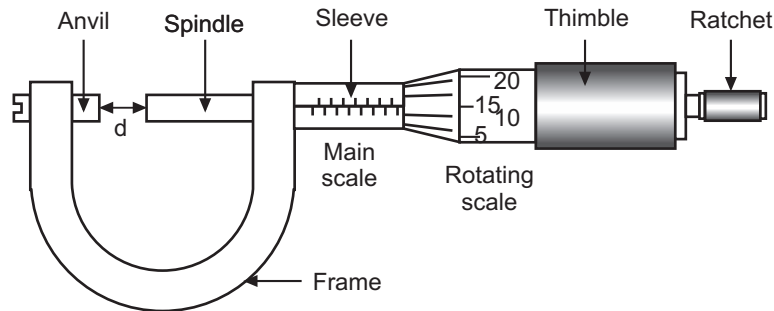

Spherometer :

It consists of a black-painted metal measuring disc and a ruler mounted on a tripod black-painted metal base. Measurements on ruler are metric, measurements on disc are imperial. It is used to determine the radius of curvature of concave and convex surfaces of mirrors and lenses.

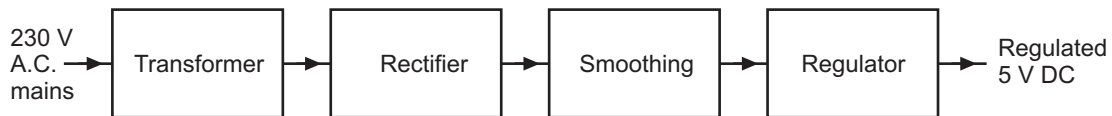

Travelling microscope :

It is an instrument for measuring length with a resolution typically in the order of 0.01 mm. The instrument comprises a microscope mounted on two rails fixed to, or part of a very rigid bed. The position of the microscope can be varied coarsely by sliding along the rails, or finely by turning a screw. The eyepiece is fitted with fine cross-hairs to fix a precise position, which is then read off the vernier scale. Travelling microscope consists of a cast iron base with machined-V-top surface and is fitted with three leveling screws. A metallic carriage, clamped to a spring-loaded bar slides with its attached vernier and reading lens along an inlaid strip of metal scale. The scale is divided in half millimeters. Fine adjustments are made by means of a micrometer screw for taking accurate reading. Microscope tube consists of 10x Eyepiece and 15 mm or 50 mm or 75 mm objectives.

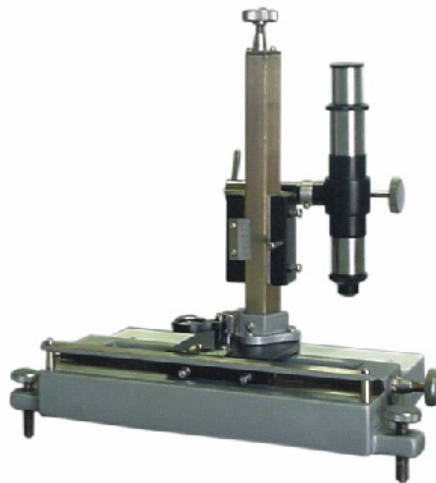

Spectrometer :

Spectrometer generally consists of entrance slit, collimator, a dispersive element, such as a grating or prism, focusing optics and detector. In a monochromatic system there is normally an exit slit and only a narrow portion of the spectrum is projected on a one-element detector. In monochromatic the entrance and exit slits are in a fixed position and can be changed in width. Rotating the grating scans the spectrum.

**Cathode Ray Oscilloscope (CRO) :**

It is a common laboratory instrument that provides accurate time and amplitude measurements of voltage signals over a wide range of frequencies. Its reliability, stability and ease of operation make it suitable as a general purpose laboratory instrument. The heart of the CRO is a cathode ray tube shown schematically in figure.

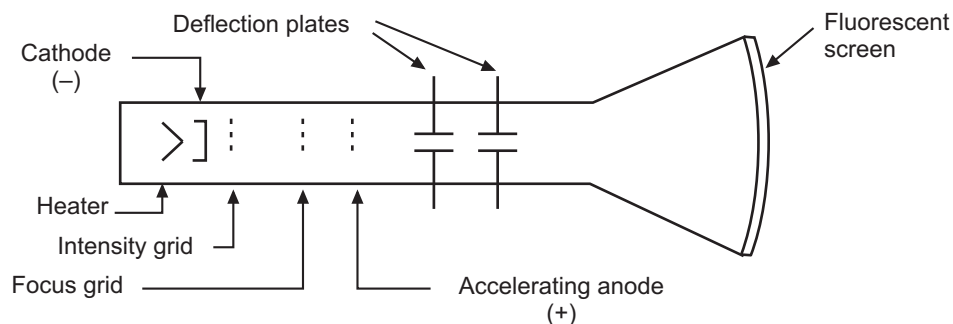

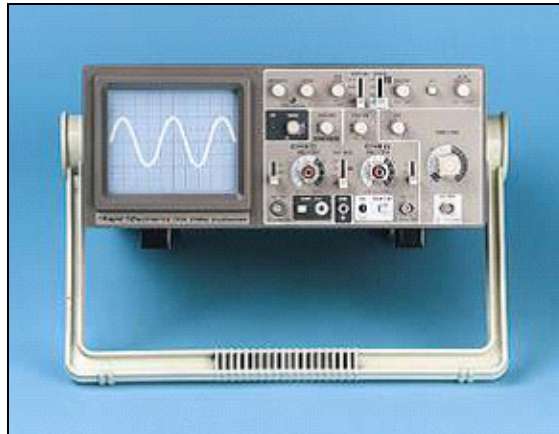
**Function Generator :**

A function generator is a device that can produce various patterns of voltage at a variety of frequencies and amplitudes. It is used to test the response of circuits to common input signals. The electrical leads from the device are attached to the ground and signal input terminals of the device under test.

**Regulated power supply :**

There are many types of power supply. Most are designed to convert high voltage AC mains electricity to a suitable low voltage supply for electronic circuits and other devices.

A power supply can be broken down into a series of blocks, each of which performs a particular function. For example a 5 V regulated supply.

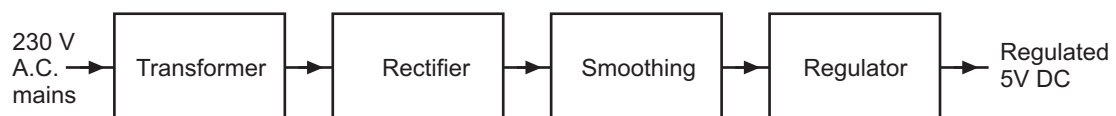

Each of the blocks is described in more detail below :

1. **Transformer** : Steps down high voltage AC mains to low voltage AC.
2. **Rectifier** : Converts AC to DC, but the DC output is varying.
3. **Smoothing** : Smooths the DC from varying greatly to a small ripple.
4. **Regulator** : Eliminates ripple by setting DC output to a fixed voltage.

Breadboard :

This is a way of making a temporary circuit, for testing purposes or to try out an idea. No soldering is required and all the components can be re-used afterwards. It is easy to change connections and replace components. Almost all the Electronics Club projects started life on a breadboard to check that the circuit worked as intended. The following figure depicts the appearance of Breadboard in which the holes in top and bottom stripes are connected horizontally that are used for power supply and ground connection conventionally and holes on middle stripes connected vertically and that are used for circuit connections conventionally.

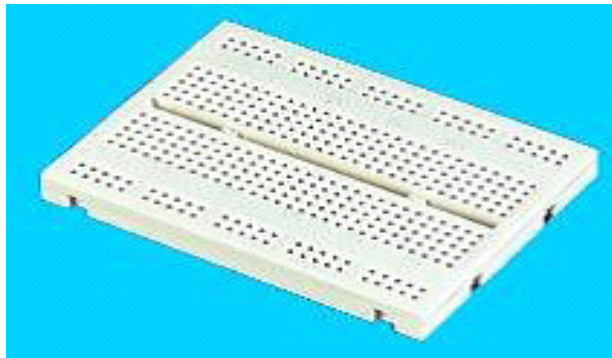

SECTION - I : GENERAL PHYSICS

EXPERIMENT NO. A-1

LOGARITHMIC DECREMENT

Aim : To determine Logarithmic decrement (λ) for air or water.

Apparatus : Disk suspended by wire, scale arrangement with stands, plane mirror, stop watch, lamp with telescope, stand, etc....

Diagram :

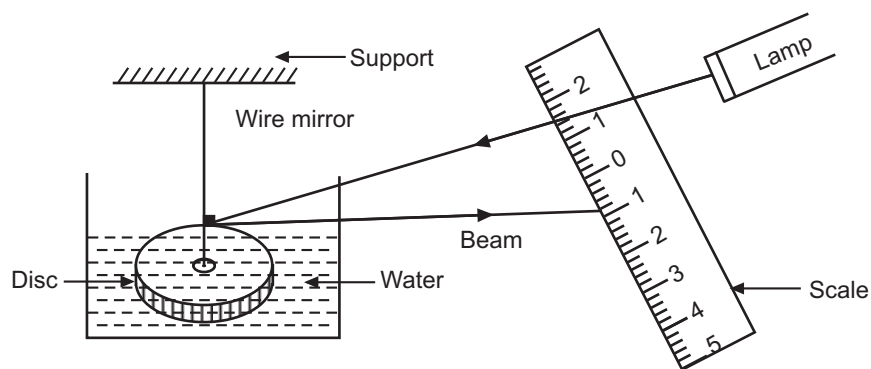

Fig.

Procedure :

- 1) Suspend the disk carefully and displace it through an angle such that the amplitude of oscillations as seen by changes in marks of the scale is over 10 cm. Measure the periodic time T in air by noting time taken for 20 oscillations.
- 2) Start the clock when the displacement is maximum (10 cm) and note the turning points on either side for 10 cycles. Allow the time measurement to continue till the displacement reduces to half of 10th cycle. Stop the clock and note the time t in sec.
- 3) Repeat the procedure for step 1 and 2 above after immersing the disk completely in water.
- 4) Draw the graph left/right turning point Vs time.

Observations :

- 1) Time for 20 Oscillations in air = time = ----- sec.
- 2) Period for oscillation in air = $T = \frac{\text{time}}{20} = \text{----- sec.}$

(1)

Practical Physics

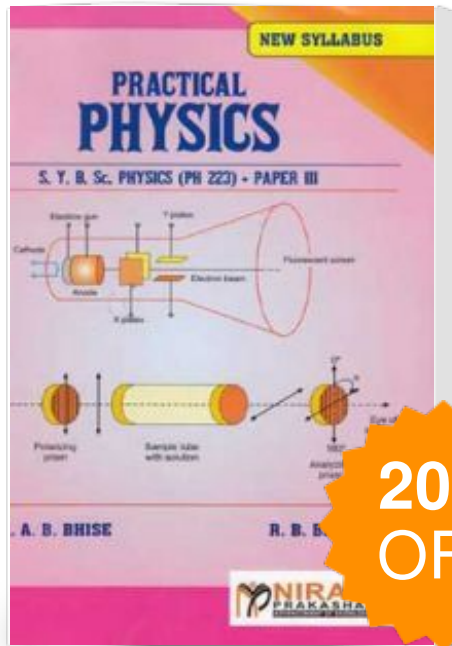

Publisher : **Nirali Prakashan**

ISBN : 9789351644620

Author : **Dr. A. B. Bhise, R. B. Bhise**

Type the URL : <http://www.kopykitab.com/product/21811>



Get this eBook